

JONELL SYSTEMS

SENTINEL™

Customizable Multi-Stage Horizontal
Coalescing Filter

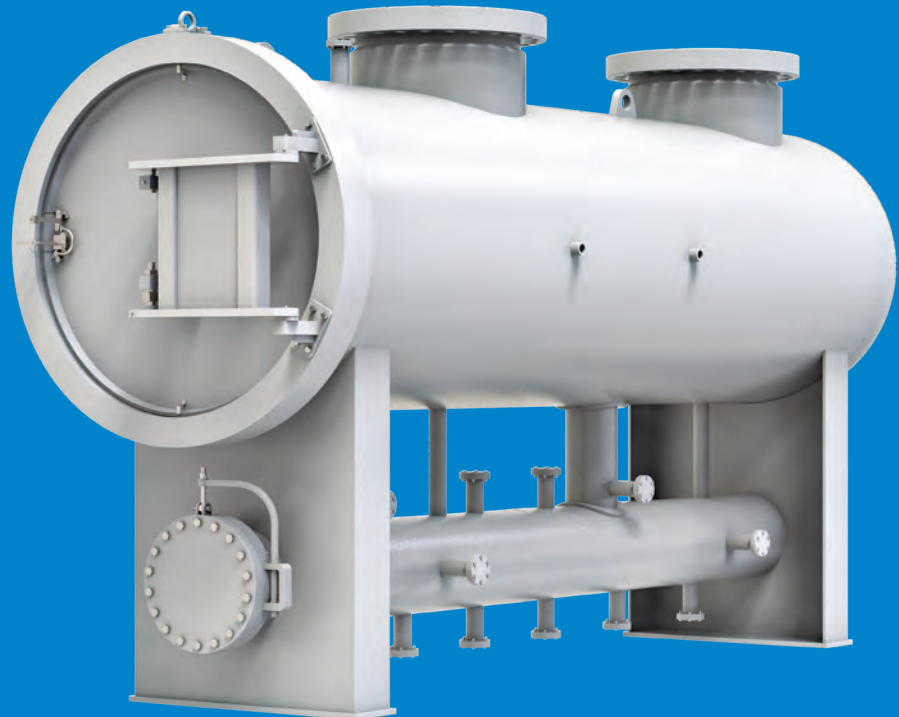

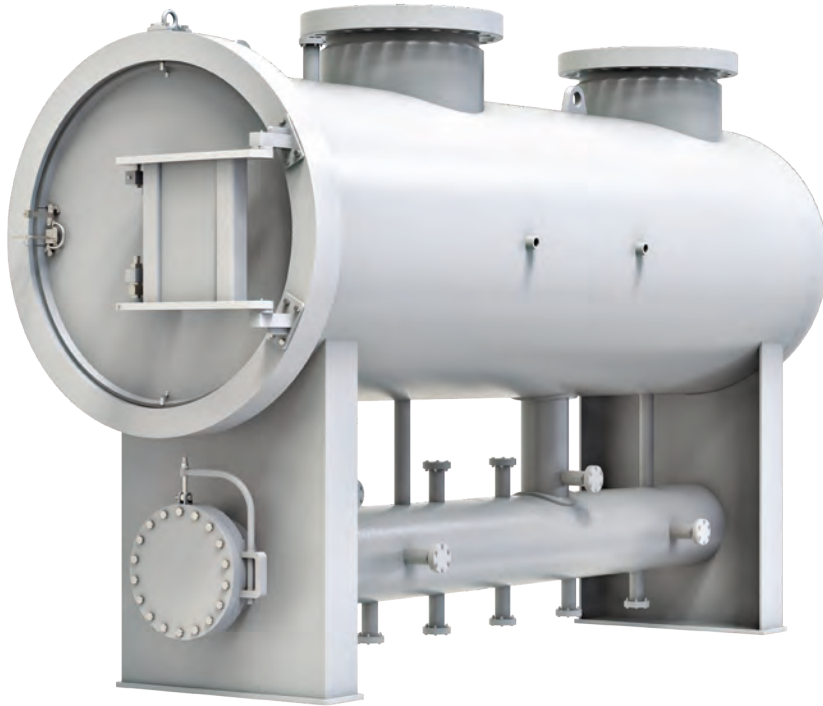

SENTINEL TL™ BY JONELL SYSTEMS

Introducing Sentinel TL™ – **Gas Processing Flexibility**

As our name implies the Sentinel TL™ is the Gate Keeper to your critical processes. Properly designed and implemented filtration equipment is paramount for the protection of your critical processes. The Sentinel TL™ features the patented Twist-LOK™ Filter Series offering a multitude of customizable element configurations allowing the equipment owner the ability to optimize filtration efficiency based on the contaminants encountered in the process flow.

This product can be applied in a myriad of applications from compressor suction and protection to final measurement and regulation stations. It can also be applied in cryogenic processing plants and dehydration process protection as pre-and post process protection. The key to this product is it is not hampered by turn down issues inherent in traditional Filtration.



Turndown

Sentinel TL™ has 100% turndown



Flexibility

Can be used as filter separator, coalescer, dust filter etc



Customizable

We can custom tailor the elements for the application



Accessibility

Once closure is open, no tools are required to change the elements

Custom Filtration Approach

Experience has taught us that processes differ from field to field, pipeline to pipeline, plant to plant, and day to day. Contaminants from different natural gas fields differ in form, shape and quantity. Therefore, a customizable filtration approach is necessary to not only protect the downstream equipment, but to optimize the filtration process. With this in mind the Sentinel TL™ with the customizable Twist-LOK™ filter elements is the only Horizontal Coalescer on the market with the flexibility to be applied in all critical protection applications.

Process Optimization

Process optimization can be done by simply changing the first or second stage element to meet the contaminant requirement. Sheer sensitive droplets or solids can be effectively collected in the first stage element without the need to change the coalescing effectiveness of the second stage element. Keeping intact the 99.9% of .3µm efficiency of the second stage and saving the end user money on change-outs.

Heavy duty ESP with double o-ring positive element sealing and machined element riser support.

Reinforced downstream element support grid for higher differential pressures and easier element installation.

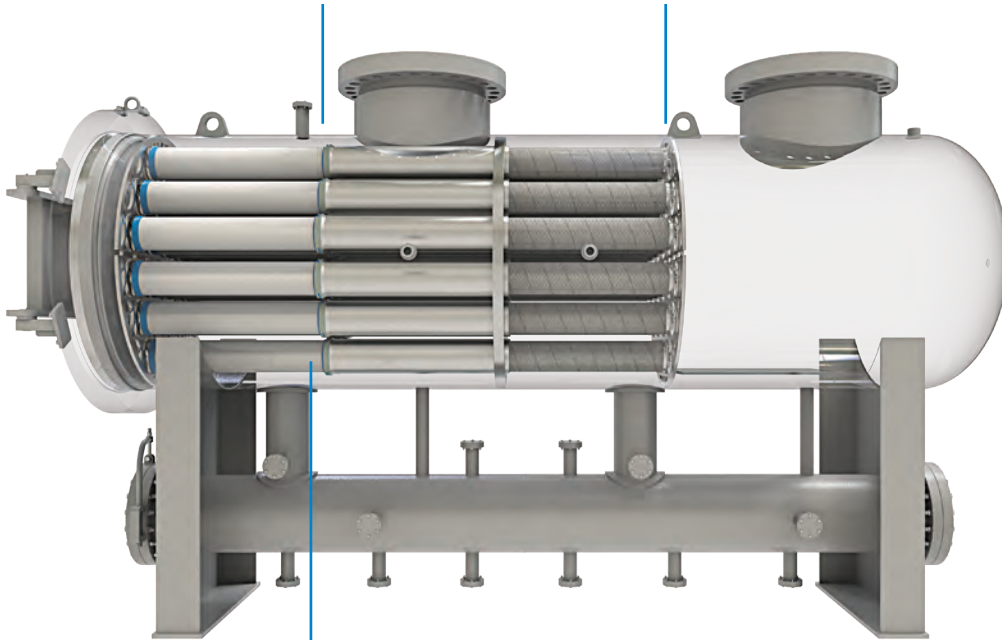

35X more contaminant capacity

Designed with the user in mind. Accepts the Twist-LOK™ two piece element for process specific customization.

Standard Vessel

8" to 72" vessel diameter- other custom sizes available

Standard Design Pressures:

ANSI 150 to ANSI 900

Maximum Operating Temp: 385°F

Standard Materials of Construction:

Carbon Steel, 304SS, and 316SS

External Attachments: Carbon Steel

Patented Twist-LOK™ Customizable Filter Elements

Design Code:

ASME Boiler & Pressure Vessel Code Section VIII Div. 1

Options

Design Codes:

PED 97/23/EC, PD5500, EN13445, GB150, and AS1210

Design Pressure:

Up to 5,000 psig

Materials of Construction:

304, 304L, 316, 316L Stainless Steel,
Low Temperature Materials

Non-destructive Test (NDT):

- Radiography
- Magnetic Particle Examination
- Liquid Penetrant Examination
- Ultrasonic Examination
- Brinell Hardness
- Charpy Impact

Coating Options:

Sandblast: commercial, near white and white metal
SSPC-SP Codes Available

Paint: 2 & 3 coat corrosion resistant

Closure Options:

- Draw Bolt, Internal Door, and Flange
- Internal Locking Door

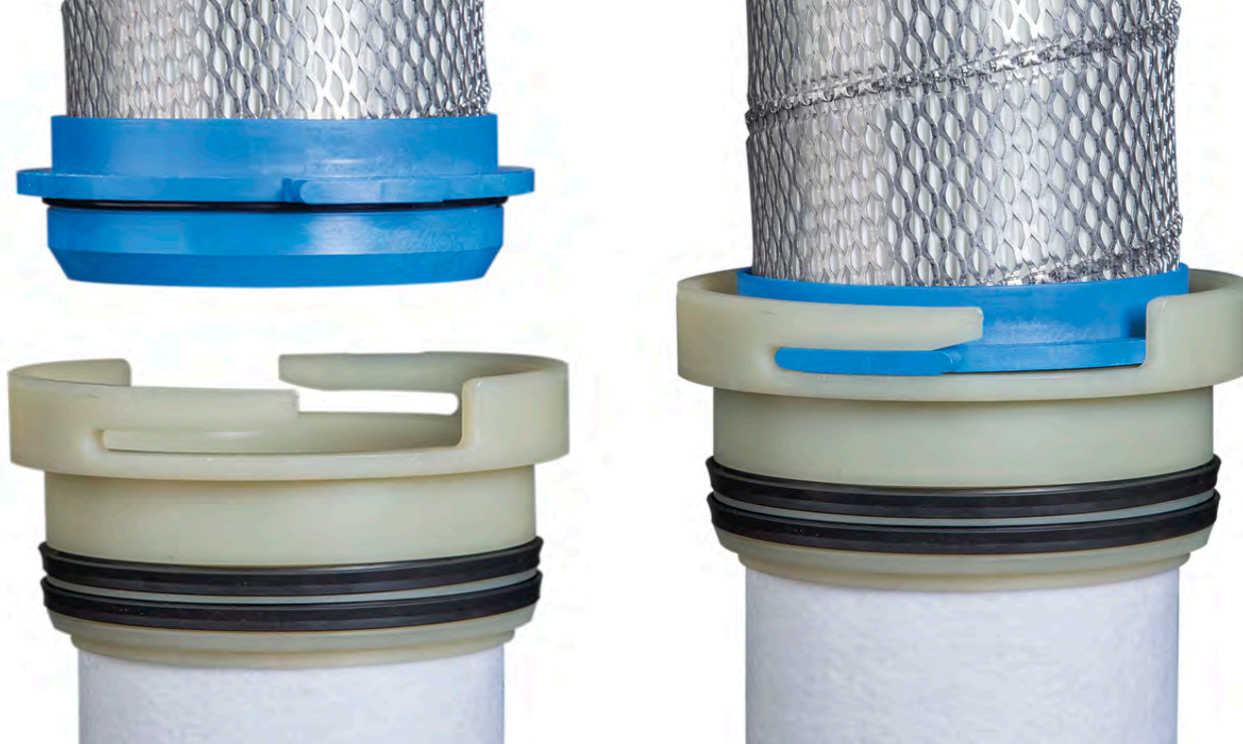

SENTINELTL™ + TWIST-LOK™

The SentinelTL features the patented Twist-LOK™ Filter Series offering a multitude of customizable element configurations allowing the equipment owner the ability to optimize filtration efficiency based on the contaminants encountered in the process flow.

Twist-LOK™ Media Configurations

Properly selecting media configurations has always been a concern when applying filtration technologies. Process applications are not always consistent and having a singular media approach is not the best solution to the ever-changing complexity of gas processing. Our approach to solving this problem is to offer the end user the ability to modify the filtration requirements “on the fly”. The below charts are only a brief listing of the media’s available to maximize your filtration requirements- other media options available.

How These Medias Compare		
Standard Media	1st Stage	2nd Stage
TRI-DEP™ POLYESTER	Ideal for applications with large liquid loading and large solid contaminant particle distributions	Ideal for applications involving semi-solids which may migrate past 1st stage pre-filter
MICRO-GLASS	Depth mirco-glass for efficient solids capture and liquid separation	High surface area micro-glass for efficient coalescing
PLEATED MICRO-GLASS	High surface area pleated media known for strong solids holding capability in relatively dry gas with strong compatibility	For use in challenging coalescing applications
PLEATED POLYESTER	High surface area pleated media known for very strong solids holding capability	Not recommended for use in second stage



Exceptional Process Improvements

Iron sulfide is a critical contaminant in natural gas pipelines. It also compromises compression equipment in pipeline, refinery, gathering, and storage applications. When the troublesome black powder clogs instrumentation and occludes valves in gas pipelines, compressors are less efficient. The damage can be significant enough to halt operations – a cost no company can afford.

Jonell Systems Twist-Lok™ elements provide the ability to improve filtration in midstream operations which result in a positive ripple effect downstream. When a leading midstream company noticed

contaminants migrating to the second stage and putting their equipment at-risk, their operators knew they needed to act fast and went to the experts.

Jonell Systems filtration specialists worked with operators to develop a customized solution for their process. After installing an optimized Twist-Lok™ configuration, and ensuring a positive sealing system, the midstream operator realized a significant reduction in harmful contaminants that were destroying critical equipment.

Problem solved.

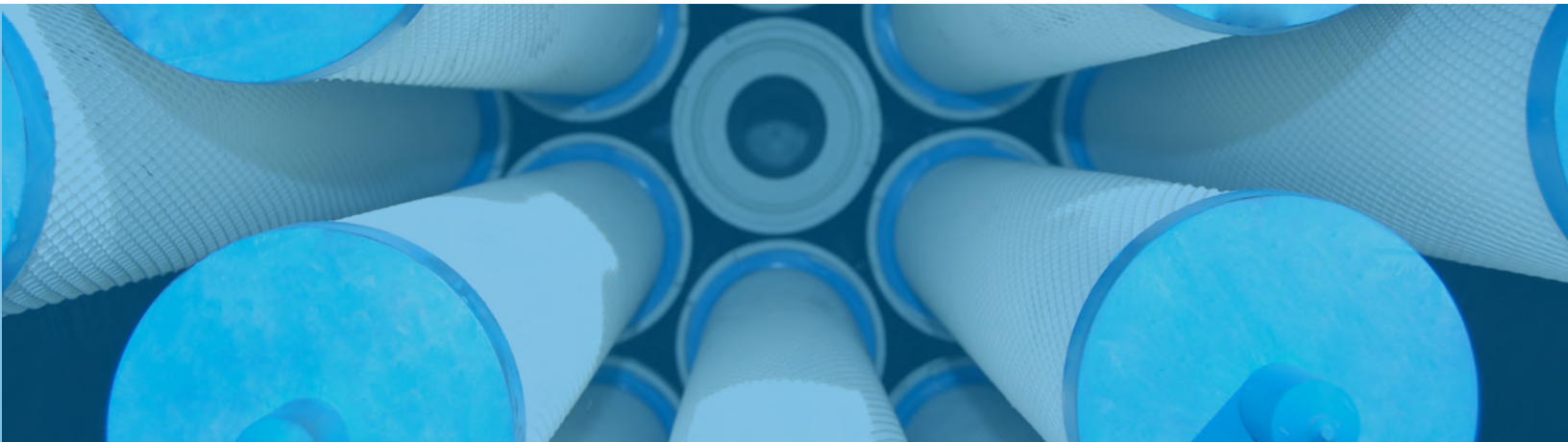

Jonell Systems, a Filtration Group brand, partners with oil, gas, refining, chemical and power companies worldwide to address end to end filtration challenges to improve process safety, reliability, productivity and ultimately business profitability. We manufacture complete systems, vessels and a wide range of cartridges to optimize your filtration processes. This coupled with our technical expertise, allows us to solve even the most challenging filtration applications.

Jonell Systems has a long history of developing innovative cartridges for the oil & gas industry including the two piece Twist-LOK™ cartridge for gas coalescing which allows customers to be able to change only half of the cartridge as needed thus reducing the total cost of ownership for the solution.

Jonell Systems also introduced SentinelTL™, a horizontal gas coalescer with 10X greater solid capacity, 35X greater liquid capacity to deliver up to 40% cost savings for customers.

As a part of Filtration Group, the world's fastest growing filtration company, it is our mission to make the world safer, healthier and more productive.

JONELL SYSTEMS ADVANTAGE

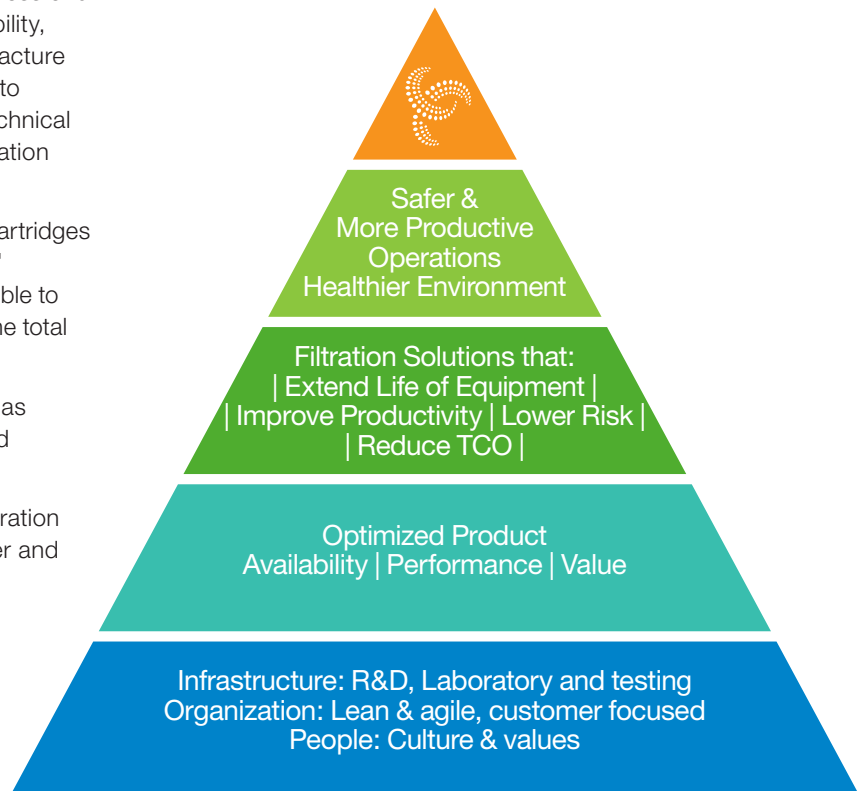

We understand our customers rely on our knowledge, expertise and experience for innovative filtration solutions.

Customers depend on us – we deliver.

Our brands include:







JONELL SYSTEMS™
Filtration Group®

Scan QR Code to find our locations



+ 1 844 GOFILTR

jonellsalesinfo@filtrationgroup.com
www.jonellsystems.com