

Sentinel TL™

CUSTOMIZABLE MULTI-STAGE HORIZONTAL COALESCING FILTER

SentinelTL™ with the customizable Twist-LOK™ filter elements is the only Horizontal Coalescer on the market with the flexibility to be applied in all critical protection applications from compressor suction and protection to final measurement and regulation stations. It can also be applied in cryogenic processing plants as pre-and post process protection. The key to this product is it is not hampered by turn down issues inherent in traditional Filtration.

This, along with proven field performance, demonstrates Jonell Systems ability to provide quality products that meet current specifications as well as specific customer requirements for installations in refineries, bulk storage, gas processing plants, etc.



STANDARD VESSEL

8" to 72" vessel diameter - other custom sizes available

Standard Design Pressures:

ANSI 150 TO ANSI 900

Maximum Operating Temp: 385°F

Standard Materials of Construction:

Carbon Steel, 304SS, and 316SS

External Attachments: Carbon Steel

Patented Twist-LOK™ Customizable Filter Elements

Design Code:

ASME Boiler & Pressure Vessel Code Section VIII Div. 1

OPTIONS

Design Codes: PED 97/23/EC, PD5500, EN13445, GB150, and AS1210

Design Pressure: Up to 5,000 psig

Materials of Construction: 304, 304L, 316, 316L Stainless Steel, Low Temperature Materials

Non-destructive Test:

- Radiography
- Magnetic Particle Examination
- Liquid Penetrant Examination
- Ultrasonic Examination
- Brinell Hardness
- Charpy Impact

Coating Options:

Sandblast; commercial near white and white metal
SSPC-SP Codes Available
Paint 2 & 3 coat corrosion resistant

Closure Options:

- Draw Bolt, Internal Door, and Flange
- Internal Locking Door

Heavy duty ESP with double o-ring positive element sealing and machined element riser support.

Reinforced downstream element support grid for higher differential pressures and easier element installation.

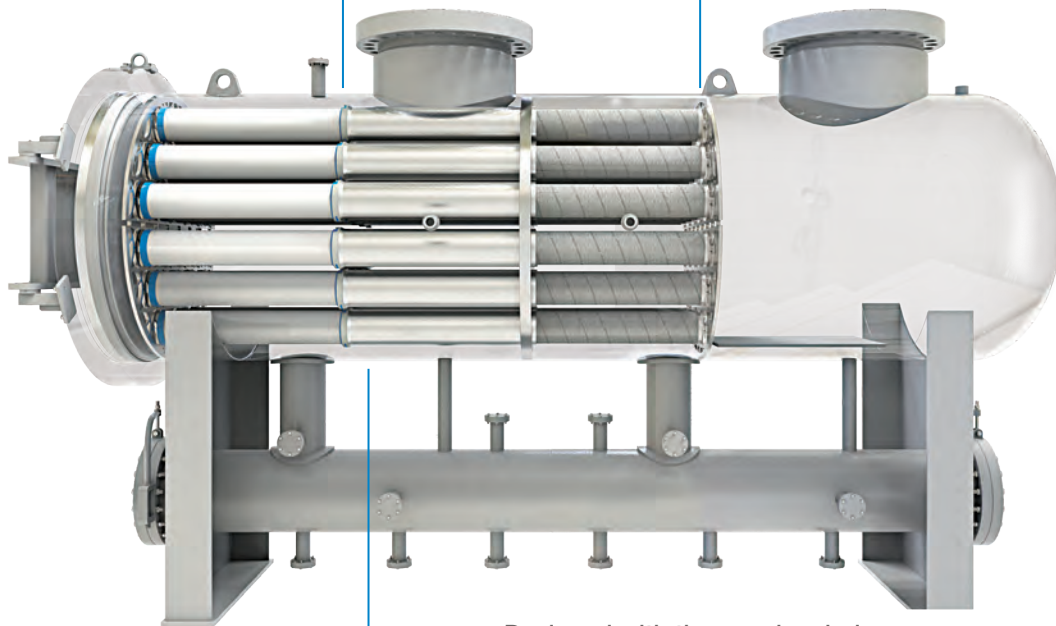

Designed with the user in mind. Accepts the Twist-LOK™ two piece element for process specific customization.

SENTINEL TL™ BY JONELL SYSTEMS

Introducing Sentinel TL™ — **Gas Processing Flexibility**

This product can be applied in a myriad of applications from compressor suction and protection to final measurement and regulation stations. It can also be applied in cryogenic processing plants as pre-and post process protection. The key to this product is it is not hampered by turn down issues inherent in traditional Filtration.



Turndown

SentinelTL™ has 100% turndown



Flexibility

Can be used as filter separator, coalescer, dust filter etc



Customizable

We can custom tailor the elements for the application



Accessibility

Once closure is open, no tools are required to change the elements

